

Operating instructions
APY Series
Peristaltic pump

realAx

ALL THE HOSE PUMP YOU'LL EVER NEED



Congratulations! **And welcome to the world of realax hose pumps.**

Drawing on extensive interaction with real users of peristaltic pumping technology and examining applications as diverse as food, water and wastewater, chemicals and pharmaceuticals, construction and mining, we have tried to tailor our range of pumps more precisely to your needs.

Our range of hoses and accessories reflect what hose pump customers really need and use – after all, best is what you want, second best should never be an option.

We hope you'll find using your realax pump simple, trouble-free and that it makes a positive contribution to the success of your process. If you have any questions you can't find answers to in these pages, check our website or call your local representative on the number on the contact page of this guide.

*Of course this manual is available in your language.
Please download it from the attached USB flash drive.*

TABLE OF CONTENTS

1	Introduction	4
2	Safety	6
3	Functional description	11
4	Description.....	12
5	Construction	13
6	Transport and storage.....	14
7	Assembly, commissioning & installation	15
8	Torque values	17
9	Troubleshooting	26
10	Spare parts.....	28
11	End of life	32
12	Declaration of conformity.....	33
13	Warranty	34
14	Where to buy	35

1 INTRODUCTION

This instruction manual must accompany the pump at all times for as long as it is in use.

The APY series peristaltic pump is a machine for fluid handling intended to be used in industrial areas, as such the instruction manual is part of the legislative provisions for the safe and correct use of the pump.

This instruction manual does not substitute any installation standard or any additional future standard.

1.1 How to use this manual

This manual is intended as a reference book by means of which qualified users are able to install, commission and maintain the hose pumps mentioned on the front cover.

1.2 Original instructions

The original instructions for this manual have been written in English. Other language versions of this manual are a translation of the original instructions.

1.3 Other supplied documentation

Documentation of components such as motors and inverters is normally not included in this manual. However, if additional documentation is supplied, you must follow the instructions in this additional documentation.

1.4 Service and support

For information with respect to specific adjustments, installation, maintenance or repair jobs which fall beyond the scope of this manual, contact your AxFlow representative. Make sure you have the serial number hose pump at hand.

1.5 Environment and disposal of waste

Enquire with your local government about the possibilities for reuse or environment friendly processing of packaging materials, (contaminated) lubricant.



CAUTION

Always observe the local rules and regulations with respect to processing (non reusable) parts of the hose pump.

2 SAFETY

2.1 Explanation of the safety information

In this manual the following symbols are used:



This symbol identifies the instructions of this manual, which must be observed to avoid failure to meet safety standards.



This symbol identifies the instructions of this manual, which must be observed to avoid compromising electrical safety.



This symbol identifies the instructions of this manual, which must be observed to guarantee the correct operation of the pump.

2.2 Intended use

The hose pump is exclusively designed for pumping suitable products. Every other or further use is not in conformance with the intended use. In case of doubt it is the use which appears to be its intended use judging from the construction, execution and function of the product. Observing the instructions in the user's documentation also belongs to intended use. Only use the pump in conformance with the intended use described above. The manufacturer cannot be held responsible for damage or harm resulting from use that is not in conformance with the intended use. If you want to change the application of your hose pump, contact your AxFlow representative first.

2.3 Responsibility

The manufacturer does not accept any responsibility for damage or harm caused by not (strictly) observing the safety regulations and instructions in this manual and the also supplied documentation, or by negligence during installation, use, maintenance and repair of the hose pumps mentioned on

the front cover. Depending on the specific working conditions or accessories used, additional safety instructions can be required.

2.4 User qualifications

Pumps are machines that can present dangers due to moving parts and the presence of a pressurised fluid within the hose.

THE FOLLOWING CAN CAUSE SERIOUS DAMAGE AND INJURY

- Improper use
- Removal of the protections and/or disconnection of protective devices
- Lack of inspections and maintenance

The person responsible for safety should therefore guarantee that the pump is transported, installed, put in service, used, maintained and repaired by qualified personnel who should possess:

- Specific training and sufficient experience for the tasks.
- Knowledge of the technical standards and applicable laws.
- Knowledge of the national and local safety and installation standards.

Any work carried out on the electrical part of the pump should be authorized by the person responsible for safety.

Given that the pump is intended to form part of a system, it is the responsibility of whoever supervises the installation of the entire system to guarantee absolute safety, adopting the necessary measures of additional protection.

2.5 General safety information



Live parts

Possible consequence: fatal or very serious injuries.

- Risk mitigation: the device must be disconnected from the power supply before it is opened.
- Isolate damaged, faulty or manipulated devices from the mains in order to de-energise.



Lack of emergency stop switch

Possible consequence: fatal or very serious injuries.

- An emergency stop switch must be connected for the entire system. This should enable the entire system to be shut down in the event of an emergency in such a way that the overall System can be brought into a safe condition.



Unauthorized access

Possible consequence: fatal or very serious injuries.

- Risk mitigation: ensure that there can be no unauthorized access to the pump or to the system.



Hazardous media/contamination of persons and equipment

Possible consequences: fatal/serious injuries. Material damage.

- Ensure that the pump hoses are chemically resistant against the media being handled.
- Always observe the safety data sheets for the media to be handled. The system operator must ensure that these safety data sheets are available and that kept up-to-date.
- The safety data sheets for the fluid being handled are always decisive for initiating countermeasures and/or first aid in the event of leakage of the fluid.
- Observe the general restrictions in relation to viscosity limits, chemical resistance and density.
- Always switch the pump off before exchanging the pump hose.

CAUTION

Incorrect and improper use

Possible consequence: fatal or very serious injuries.

- The unit is not intended to convey or regulate gases or solid media
- Do not exceed the rated pressure, speed or temperature for the pump
- Maximum pressure on suction/inlet side is 0.5 bar (7 psi approx.).
- The unit may only be used in accordance with the technical data and specifications provided in these operating instructions and in the operating instructions for the individual components.
- This pump is NOT supplied for use in areas of risk from explosion. ATEX versions of Realax pumps are available and they are supplied with a special ATEX version of the instruction manual.
- Only switch the pump on if it has been properly fastened to the floor.
- Only switch the pump on if the front cover has been attached.
- Do not carry out any maintenance operations or dismantle the pump without first making sure that the pipes are not under pressure and are empty or isolated.
- In the case of the hose becoming stuck during extraction or fitting it is necessary to reverse the direction of the pump, re-lubricate, and then repeat the operation.
- As the peristaltic pump is volumetric and its functioning is positive displacement, it is necessary to prevent a possible overload of pressure, due to for example the accidental closure of a valve. For this reason it is advisable to fit a safety device such as: a safety valve, pressure limiter, etc.

CAUTION

Operational lifetime of the pump hoses

Possible consequence: fatal or very serious injuries.

- The hose has an indeterminate life and due to the possibility of its breakage or deterioration, the user is responsible for the prevention of a possible

(although most unlikely) incorporation of particles from the hose into the product being pumped. This can be achieved by means of filtration, a hose rupture alarm or other means suitable for the respective process.



CIP cleaning

- In the event of CIP cleaning, it is necessary to obtain information from the manufacturer about correct installation of the pump (a special installation is required) as well as regarding the compatibility of the cleaning agents with the pump hoses and the hydraulic connections.
- Cleaning should be undertaken at the recommended maximum temperature.



Direction of rotation/flow direction

Possible consequence: material damage, destruction of the unit.

- The pump's direction of rotation in relation to the desired flow direction must be checked prior to every start.



Disconnect the pump from the mains

Possible consequence: personal injury.

- Work may only be carried out on the pump after it has previously been switched off and disconnected from the mains.



Environmental influences

Possible consequence: material damage up to destruction of the unit.

- The device is suitable for outdoor operation once it is covered and protected from rain and direct sunlight. Ambient conditions must also be respected (*see section 8.1*).
- Take suitable measures to protect the device from environmental influences such as: UV rays | moisture | frost | etc.

3 FUNCTIONAL DESCRIPTION

The APY Series is a positive displacement pump. The feed chemical is conveyed by the rotor squeezing the tube in the direction of flow. No valves are needed for this. This ensures gentle handling of the metered media.

Maximum pressure on suction/inlet side is 0.5 bar (7 psi approx.)
The APY Series has been designed for safe and uncomplicated operation, as well as straightforward maintenance.

The APY Series can be used for many different media. However, this pump type is often the optimal solution for abrasive, shear-sensitive and viscous media.

Typical areas of use include processes where only a low discharge pressure is required (max. 2 bar).

3.1 Main modules

1. Drive unit | 2. Pump housing | 3. Base frame

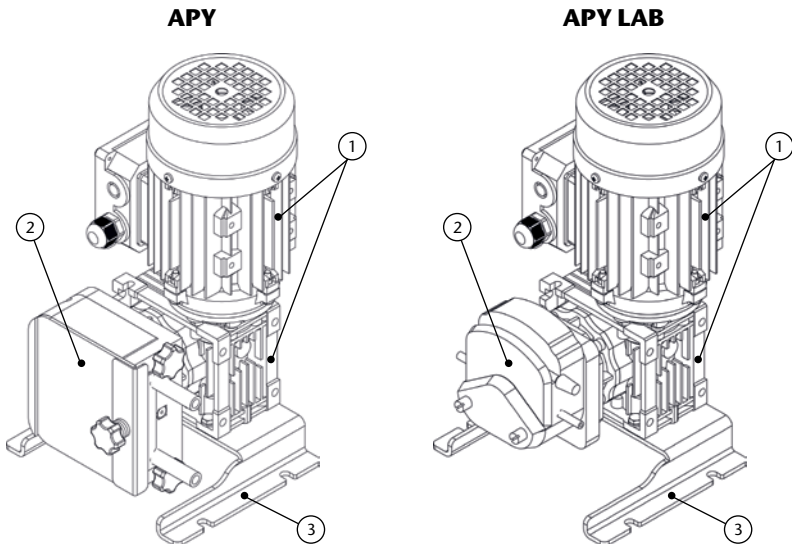

Key performance data and noise levels

DESCRIPTION	UNIT	TUBE (Ø)	APY	APY/LAB
Max. Capacity Continuous Duty	l/h	–	84	38.2
Max. Capacity Intermittent Duty	l/h	–	84	38.2
Capacity per Revolution	ml/rev	1.6 mm	0.40	–
		3.2 mm	1.66	0.75
		4.8 mm	3.80	1.72
		6.4 mm	6.26	2.54
		8.0 mm	10.00	4.55
Max. Permissible Working Pressure	bar	–	2	
Permissible Ambient Temperature	°C	–	-10 to +40	
Permissible Product Temperature	°C	–	-10 to +80	
Sound Level at 1m	dB (A)	–	70	

4 DESCRIPTION

4.1 Identification of the product

A: Pump head

B: Gearbox

C: Electric motor

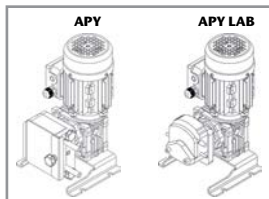

4.2 Identification of the pump

MOD: Type number

N°: Serial number

YEAR: Year of manufacture



4.3 Identification of the gearbox (B)

The gearbox has an identity plate with the model, serial number and manufacturer's details as well as information relevant to its function such as reduction ratio.

4.4 Identification of the electric motor (C)

The motor has an identity plate with the model, serial number and manufacturer's details as well as information relevant to its' function such as electric power.

5 CONSTRUCTION

The pump housing is closed off with a bolted front cover in order to avoid the risk of injury.

The motor serves to drive the rotor. Three rollers attached to the rotor serve to press the tube against the pump housing.

The rotary movement of the rotor alternately presses and releases the rollers against the tube. This serves to suck the media and convey it into the metering line.

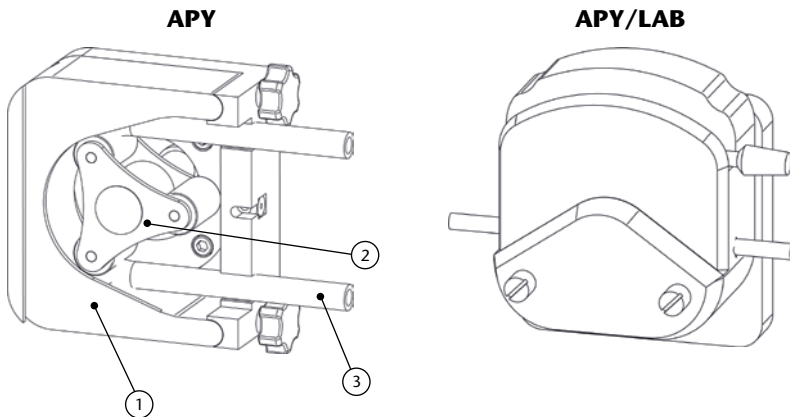

Fig. 1: Diagram of functional principle
1. Pump housing | 2. Rotor | 3. Tube

6 TRANSPORT AND STORAGE

6.1 Transport

- The pump is protected by cardboard packaging or a wooden crate.
- The packaging materials are recyclable.

6.2 Storage for less than 1 month

- The pump should be in a resting position, rotor in horizontal position.
- Avoid areas open to harsh weather or excessive humidity and temperatures lower than 0 °C or higher than 30 °C.
- Spare tubes should be stored in a dry place away from direct light.

6.3 Storage for more than 1 month

- Avoid areas open to harsh weather or excessive humidity and temperatures lower than 0 °C or higher than 30 °C.
- **IMPORTANT** Disassemble the tube from the housing (see section 8.2)
- For storage periods of longer than 30 days, protect the coupling surfaces (clamps, reducers, motors) with adequate anti-rust protection.
- For storage periods longer than 6 months rotate the rotor a few turns to prevent damage to bearings and oil seals and to prevent grease migration.
- Spare tubes should be stored in a dry place away from direct light.

6.4 Elevation

APY pumps sizes can be lifted manually and can be lifted by one person. It is the customer's responsibility to adhere to local workplace legislation.

WEIGHTS	APY	APY/LAB
Total pump weight	<11 kg <24.25 lbs	
Lifting	1 person	

7 ASSEMBLY, COMMISSIONING AND INSTALLATION

7.1 Ambient conditions

Assembly is to be carried out in the following order.

If the pump has to be installed outdoors, then it is to be equipped with protection against sunlight and weather influences.

When positioning the pump, ensure that sufficient room for access is provided for all types of maintenance work.

Limit values for hose temperature and pressure

Tube Material	Min. Temp. (°C) Feed liquid	Max. Temp (°C) Feed liquid	Min. Temp (°C) Environment	Max. Pressure (bar)
NORPRENE	-10	80*	-10	2
SOLVA				3
SILICONE				2

** At max. temperature, the life of tube is drastically reduced. Please contact authorized distributor for applications with feed liquid temperature higher than 60 °C.*

7.2 Commissioning

7.2.1 Testing prior to commissioning the pump

The following tests are to be carried out:

- Only switch the pump on if the front cover has been properly attached.
- Check that the mains voltage is suitable for the motor.
- Check that the thermal overload protection (not included in the delivery scope) corresponds to the value specified on the motor type plate.
- Confirm that pump has been properly earthed.
- Connect the electric motor according to local applicable rules and regulations. The electrical installation work must be carried out by qualified personnel.
- Check that the optional electrical components are connected and are working properly.
- Check whether the direction of rotation is correctly adjusted.

7.3 Correct installation of the pump

- Ensure that the pump has not been damaged during transportation or storage. Immediately report any damage to the supplier.
- Ensure that all the packaging has been removed.
- Check that the information printed on the identification plate corresponds with the order.
- Check the operating instructions in order to ensure that the flow values, pressures & power consumption of the motor do not exceed rated values.
- Ensure that the tube is suitable for the fluid to be conveyed and that it is not damaged.
- Make sure that the temperature of the liquid does not exceed the recommended temperature range.
- Ensure that there is enough space for free airflow around the motor.
- Ensure that no nearby objects or direct sunshine radiate additional heat to the motor.

7.3.1 Suction side

- The pump is to be positioned as near as possible to the liquid container, so that the suction side is kept as short and straight as possible.
- The suction line must be absolutely airtight and made of a suitable material, so that it does not collapse under vacuum.
- The diameter must correspond to the rated diameter of the tube. A larger diameter is recommended in the event of viscous liquids.
- The pump is self-priming and does not require an admission valve.
- The pump is reversible and the suction side can be connected to either hydraulic connection of the pump. Normally the option is selected which is best suited to the physical conditions of the rest of the installation.

7.4.1 Discharge side

- The discharge line is to be kept as straight and short as possible, in order to avoid performance reduction.
- The diameter must correspond to the rated diameter of the tube. A larger diameter is recommended in the event of viscous liquids.
- Do not close or block the outlet since, as it is a volumetric pump, it would cause the tube to break or an electro-mechanical overload.

8 TORQUE VALUES

	DESCRIPTION	UNITS	APY
A	Cover bolts	-	Manual, no bolts
B			

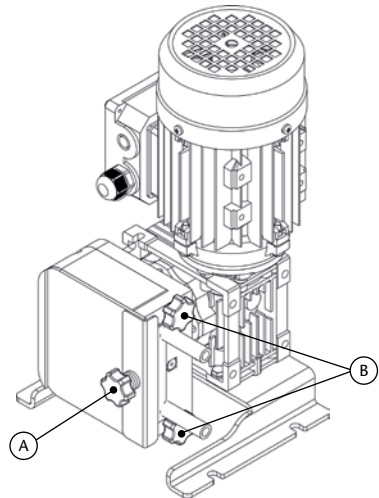

8.1 Lubrication

APY pumps only require a thin film of grease to reduce the friction between the roller and the outer surface of the tube. No other lubrication is necessary.

Lubricant quantity table

	UNIT	APY
Lubricant	-	realax
Silicone grease quantity	gramme	10-20
	ounce	0.35 – 0.71

8.1.1 Changing oil in gearbox

The instructions manual of the gearbox are usually delivered with the IOM of the relax pump.

Some models of gearbox are lubricated for life, other models of gear reducers require regular maintenance according to the instructions manual of the gear reducer manufacturer.

In case of doubt, please contact the gearbox manufacturer or their authorised distributor in your country.

8.2 Exchanging the APY tube

8.2.1 Dismantling

Close off all valves, in order to prevent leakage of the feed chemical.

1. Dismantle the pipes from both discharge and suction sides.
2. Remove the front cover. Front covers of APY series can be removed manually.



-
3. Insert an allen key into bolt on the left of the housing to stop the bolt from rotating and twist off the star knob on the right.



4. Slide off the removable housing.

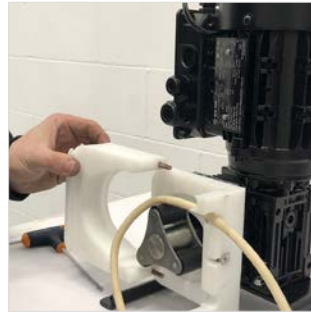

5. Clean removable housing and rollers.



6. Apply lubricant to the rollers and the removable housing with a small brush.



7. Place new tube around the roller and through the slots in the housing.



8. Place the allen screws in the removable housing and slide it on the housing.

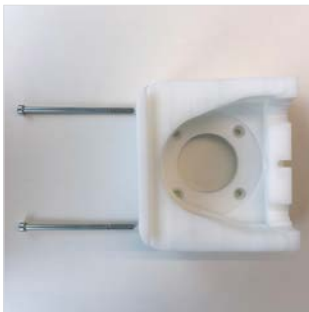

-
9. Use the allen key to stop the bolt from rotating and twist the star knob until both parts of the housing are in contact.



10. Install the front cover.



11. Begin to twist the star knob.



12. With one hand pull on the tube *without stretching* it and with the other hand continue to twist the star knob until the front cover is closed.



13. The tube changing process is complete. To check that the tube is correctly held in place, pull on one end to make sure that no movement is possible.



14. Mount the pipes from both discharge and suction sides.

15. Open all of the valves.

8.3 Exchanging the APY-LAB tube

8.3.1 Dismantling

Close off all valves, in order to prevent leakage of the feed chemical.

1. Dismantle the pipes from both discharge and suction sides. Lift the lever.



2. Remove tube.

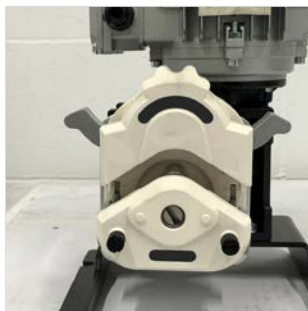

3. Position the new tube.
4. Lower the lever.
5. Mount the pipes from both discharge and suction sides.
6. Open all of the valves.

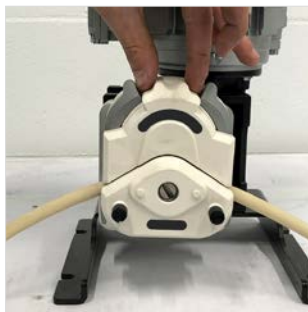

8.4 Replacement of electric motor

For repair or replacement of the electric motor they could be disassembled from the pump housing.

The pump is stable on its baseplate and will not fall over when the electric motor is disassembled. No support set is necessary.

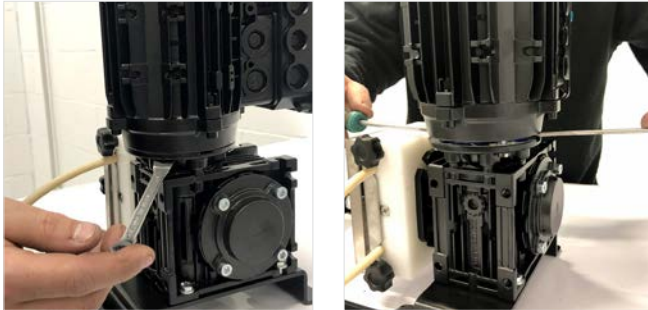

8.5 Addition of leak detection sensor

Standard APY pump housing is not prepared for addition of leak detection sensor.

The alternative is to order the APY pump assembled onto a collector with its own leakage detector

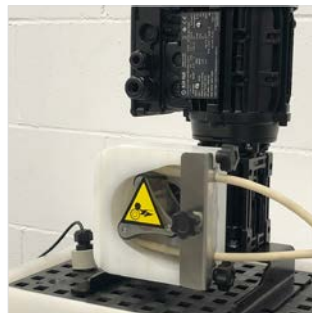

Troubleshooting

Spare parts

End of life

9 TROUBLESHOOTING

PROBLEM	POSSIBLE CAUSE	SOLUTION
Increased pump temperature	Tube has no lubricant	Lubricate tube
	Increased product temperature	Reduce product temperature
	Insufficient or poor suction conditions	Check suction line condition
	Pump speed too high	Reduce pump speed
Reduced flow or pressure	Valves on discharge and or suction side completely or partially closed	Open valves
	Tube insufficiently compressed	Check roller fastening
	Tube rupture (the product leaks out into the housing)	Exchange tube and clean pump
	Partial blockage of the suction line	Clean pipe
	Insufficient product quantity in storage container	Fill storage container or exchange pump
	Insufficient diameter on the suction side	Increase the diameter on the suction side, as far as possible
	Suction line too long	Shorten the suction line, as far as possible
	High viscosity of medium	Reduce viscosity, as far as possible
	Air introduction in the suction connections	Check connections and accessories for air tightness
	High pulsation on suction	Tighten connections and accessories Mount anti-pulsation equipment. Reconsider application (speed, etc.)
Vibrations on pumps and pipelines	The pipes are not correctly fastened	Fasten pipes correctly (e.g. wall brackets)
	Pump speed too high	Reduce pump speed
	Insufficient nominal width of the pipes	Increase nominal width
	Pump base plate loose	Fasten base plate
	Pulsation dampers insufficient or missing	Install pulsation dampers on suction and / or discharge side

PROBLEM	POSSIBLE CAUSE	SOLUTION
Short operational lifetime of the hoses	Chemical exposure	Check the compatibility of the tube with the liquid being conveyed, the cleaning fluid and the lubricant
	High pump speed	Reduce pump speed
	High conveying temperature	Reduce product temperature
	High operating pressure	Reduce operating pressure
	Pump cavitation	Check the suction conditions
	Abnormal elevation of temperature	Check rollers fast mounting
	Unsuitable lubricant	Use relax lubricant
	Insufficient quantity of grease	Reapply lubricant
Tube pulled into the pump housing	High inlet pressure (> 0.5 bar)	Reduce inlet pressure
	Tube filled with deposits	Clean or replace the tube
	Holder (press connection) insufficiently tightened	Re-tighten holder (press connection)
	Insufficient grease	Reapply lubricant
The pump does not start up	Insufficient motor performance	Check motor and replace if necessary
	Insufficient output from frequency converter	The frequency converter must match the motor
	Blockage in the pump	Check voltage. Start occurs at minimum 10 Hz
	Blockage in the pump	Check if the suction or discharge side is blocked. Rectify blockage

10 SPARE PARTS

10.1 Spare parts exploded APY Model

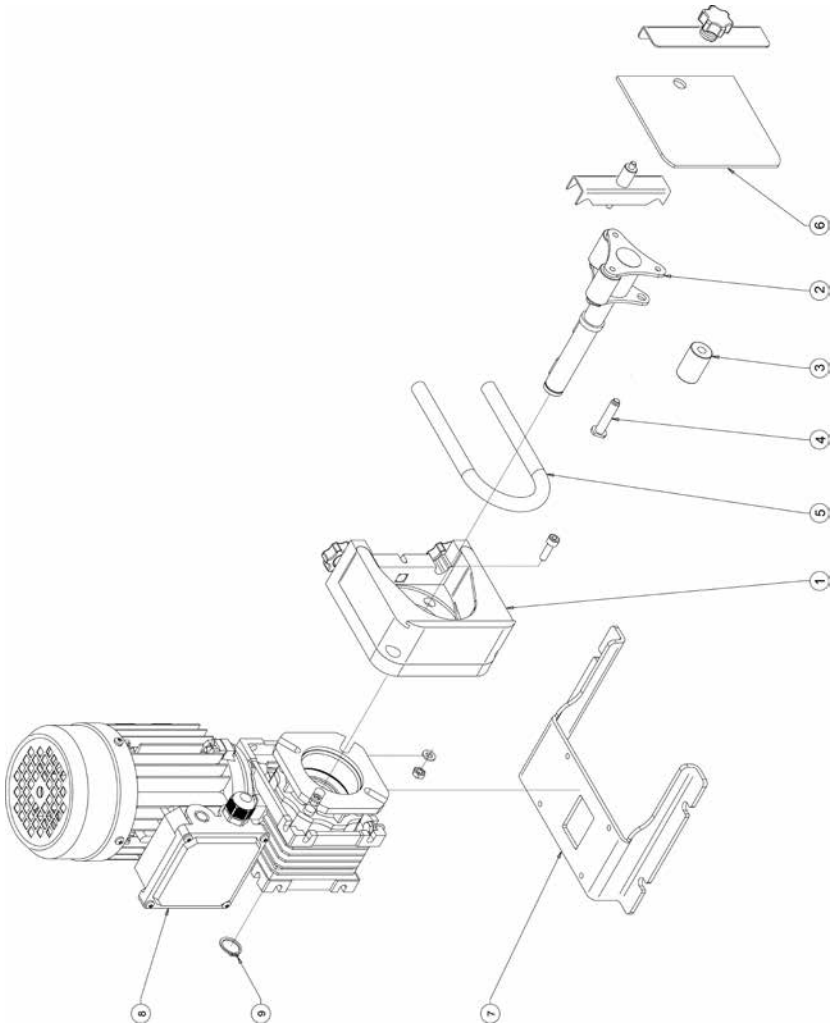

POS.	DESCRIPTION	QUANTITY	REFERENCE
1	Pump Housing	1	AX115.99.02
2	Rotor	1	AX115.00.04
3	Roller (2.4 mm tube wall thickness)	3	AX115.00.05
	Roller (1.6 mm tube wall thickness)	3	AX115.00.07
4	Roller shaft	1	AX115.00.09
5	Peristaltic Tube ØId.1.6x2.4mm SILICONE APY	1	AXSIL-16.24.05
	Peristaltic Tube ØId.3.2x2.4mm SILICONE APY	1	AXSIL-32.24.05
	Peristaltic Tube ØId.4.8x2.4mm SILICONE APY	1	AXSIL-48.24.05
	Peristaltic Tube ØId.6.4x2.4mm SILICONE APY	1	AXSIL-64.24.05
	Peristaltic Tube ØId.8.0x2.4mm SILICONE APY	1	AXSIL-80.24.05
	Peristaltic Tube ØId.4.8x2.4mm NORPRENE G APY	1	AXNORG-48.24.05
	Peristaltic Tube ØId.6.4x2.4mm NORPRENE G APY	1	AXNORG-64.24.05
	Peristaltic Tube ØId.8.0x2.4mm NORPRENE G APY	1	AXNORG-80.24.05
	Peristaltic Tube ØId.1.6x2.4mm NORPRENE F APY	1	AXNORF-16.24.05
	Peristaltic Tube ØId.3.2x2.4mm NORPRENE F APY	1	AXNORF-32.24.05
	Peristaltic Tube ØId.4.8x2.4mm NORPRENE F APY	1	AXNORF-48.24.05
	Peristaltic Tube ØId.6.4x2.4mm NORPRENE F APY	1	AXNORF-64.24.05
	Peristaltic Tube ØId.8.0x2.4mm NORPRENE F APY	1	AXNORF-80.24.05
	Peristaltic Tube ØId.3.2x2.4mm SOLVA APY	1	AXSOL-32.24.05
	Peristaltic Tube ØId.4.8x2.4mm SOLVA APY	1	AXSOL-48.24.05
	Peristaltic Tube ØId.6.4x2.4mm SOLVA APY	1	AXSOL-64.24.05
Peristaltic Tube ØId.8.0x2.4mm SOLVA APY	1	AXSOL-80.24.05	
6	Polycarbonate cover APY	1	AX115.00.16
7	Base plate	4	AX115.00.14
	Base plate S.S.	4	AX115.00.15
8	Driver	4	
9	Seeger ring Shaft APY	8	AX115.00.10

10.2 Spare parts exploded APY / LAB Model

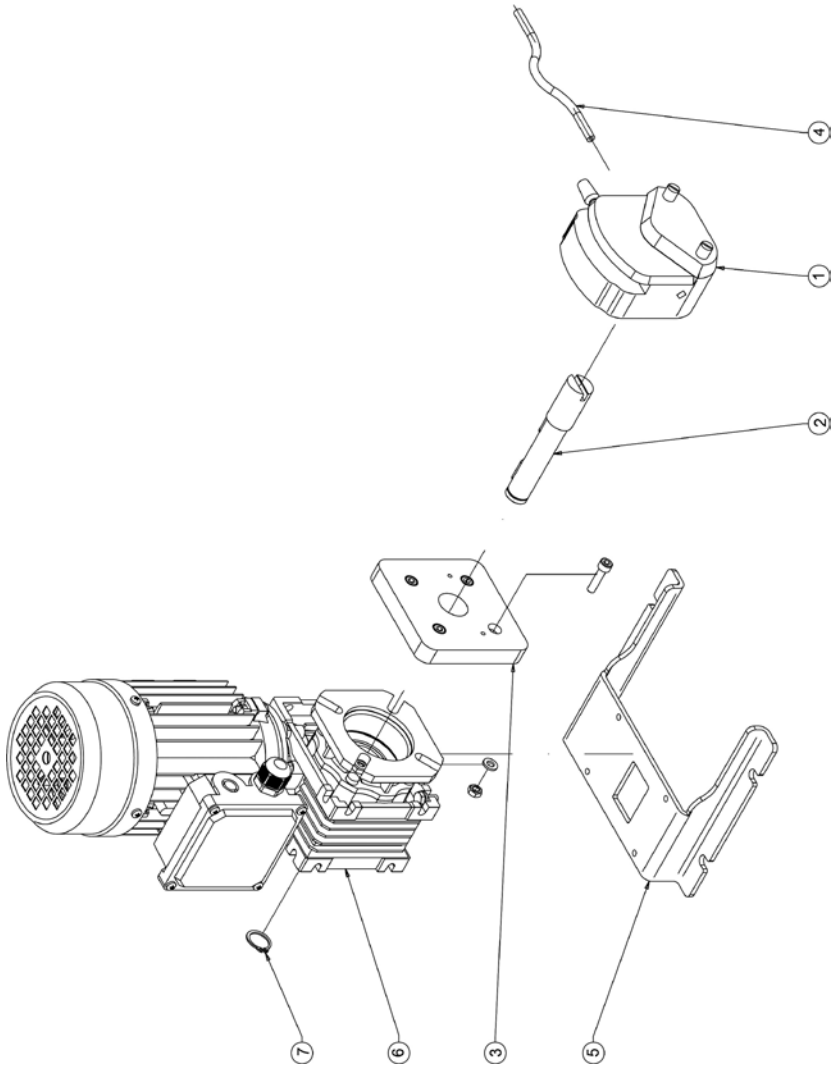

POS.	DESCRIPTION	QUANTITY	REFERENCE
1	Pump Head APY/LAB	1	AX115.00.75
2	Shaft APY/LAB	1	AX115.00.77
3	Intermediate Plate APY/LAB	1	AX115.00.76
4	Peristaltic Tube ØId.1.6x2.4mm SILICONE APY	1	AXSIL-16.24.05
	Peristaltic Tube ØId.3.2x2.4mm SILICONE APY	1	AXSIL-32.24.05
	Peristaltic Tube ØId.4.8x2.4mm SILICONE APY	1	AXSIL-48.24.05
	Peristaltic Tube ØId.6.4x2.4mm SILICONE APY	1	AXSIL-64.24.05
	Peristaltic Tube ØId.8.0x2.4mm SILICONE APY	1	AXSIL-80.24.05
	Peristaltic Tube ØId.4.8x2.4mm NORPRENE G APY	1	AXNORG-48.24.05
	Peristaltic Tube ØId.6.4x2.4mm NORPRENE G APY	1	AXNORG-64.24.05
	Peristaltic Tube ØId.8.0x2.4mm NORPRENE G APY	1	AXNORG-80.24.05
	Peristaltic Tube ØId.1.6x2.4mm NORPRENE F APY	1	AXNORF-16.24.05
	Peristaltic Tube ØId.3.2x2.4mm NORPRENE F APY	1	AXNORF-32.24.05
	Peristaltic Tube ØId.4.8x2.4mm NORPRENE F APY	1	AXNORF-48.24.05
	Peristaltic Tube ØId.6.4x2.4mm NORPRENE F APY	1	AXNORF-64.24.05
	Peristaltic Tube ØId.8.0x2.4mm NORPRENE F APY	1	AXNORF-80.24.05
	Peristaltic Tube ØId.3.2x2.4mm SOLVA APY	1	AXSOL-32.24.05
	Peristaltic Tube ØId.4.8x2.4mm SOLVA APY	1	AXSOL-48.24.05
	Peristaltic Tube ØId.6.4x2.4mm SOLVA APY	1	AXSOL-64.24.05
Peristaltic Tube ØId.8.0x2.4mm SOLVA APY	1	AXSOL-80.24.05	
5	Base plate	1	AX115.00.14
	Base plate S.S.	1	AX115.00.15
6	Driver	1	
7	Seeger ring Shaft APY	1	AX115.00.10

11 END-OF-LIFE



WARNING! Danger from hazardous substances!
Possible consequence: Fatal or very serious injuries.
Customer must decontaminate the pump with suitable agents (refer to the material safety data sheet for the fluid).

11.1 Recycling

Once cleaned the following components can be scrapped/recycled:

- Pump housing
- Rotor and rollers
- Baseplate
- Drive - Some specialist disassembly may be required.

11.2 Recycling and/or Repurposing

The following components even when cleaned must still be prepared for special waste disposal.

Customer is responsible to follow local legislation for reuse or environmentally friendly processing of packaging materials, (contaminated) lubricant, oil and the following components.

- Tube
- Plastic

Once the hose has been cleaned it may be disposed of using the same methods as car tyre disposal – *follow local regulations.*

12 DECLARATION OF CONFORMITY

- Original -
EC Declaration of Conformity

We hereby declare,

AxFlow Holding AB
Sveavägen 151, floor 5
SE-113 46 Stockholm
Sweden

That the following designated product complies with the pertinent fundamental safety and health requirements of the EC Directive in term of its design and construction and in term of the version marketed by us.

This declaration loses its validity in the event of a modification to the product not agreed with us.

Description of the product: Peristaltic pump RealAx APY / LAB model

Product Type: APY /LAB

Serial no: Refer to nameplate on the device

Pertinent EC Directives: **CE Declaration of Conformity (Ann. II. A 2006/42/CE):**
The pump is conformity to the safety requirements according to the 2006/42/CE norms and amendments.

Manufacture Declaration (Ann. II. B 2006/42/CE): The pump cannot be operated before the machine in which is assembled the pump, will be declared in conformity with the safety requirements according to the 2006/42/CE norms and requirements.

Signature:



Details of the signatory:

David Lindquist

PLC Peristaltic Pumps, AxFlow Holding AB

13 WARRANTY

We guarantee against all manufacturing defects and guarantee the materials that compose the relax pump for two years from the date of delivery. This guarantee does not cover the hose or the lubricant as these are elements that have a normal function wear, irrespective of their duration.

This guarantee is valid as long as the equipment is operated in accordance with this document.

This guarantee includes materials and work but not the cost for transportation of the equipment to the authorized repair shop or its return to the customer.

AT

Für weitere Informationen über realax Schlauchpumpen und für Service und Support kontaktieren Sie bitte:

AxFlow GesmbH
Seering 2/2. OG
8141 Premstätten, Österreich
Tel.: +43 316 68 35 09-0
Fax: +43 316 68 34 92
E-mail: office@axflow.at
www.axflow.at

BG

For more information about realax hose pumps please contact:

AxFlow Ltd.
27 Prof. Kiril Popov Street, ground floor
Sofia city
Tel.: +359 (0) 879 380 202
E-mail: service.bulgaria@axflow.hu

CH

Für weitere Informationen und umfassenden Service wenden Sie sich bitte an:

AxFlow GmbH
Vertriebsbüro Schweiz
Eptingerstrasse 41
4132 Muttenz, Schweiz
Tel.: +41 61 4619691
E-mail: info@axflow.ch

CRO

Za servisiranje i podršku vaših realax peristaltičkih pumpi sa obratite se na adresu:

VIP Tehnika d.o.o.
– Member of AxFlow Group
Zgornji Duplek 30e
2241 Spodnji Duplek
Tel.: +386 2 684 00 60
Fax: +386 2 681 01 62
E-Mail: vip.tehnika@siol.net
www.vip-tehnika.si/

DE

Für weitere Informationen und umfassenden Service wenden Sie sich bitte an:

Beratung, Verkauf und Service
AxFlow GmbH
Theodorstrasse 105
40472 Düsseldorf, Deutschland
Tel.: +49 211 23806-0
E-mail: info@axflow.de

Service-Stützpunkt und Werkstatt

AxFlow Service Süd
Kiryat-Shmona-Straße 11
87700 Memmingen, Deutschland
Tel. +49 8331 3309
service.sued@axflow.de

DK

For service og support til dine realax slangepumper kontakt venligst:

AxFlow A/S
Omstillingen: +45 7010 3550
Bestillinger, forespørgsler og almene spørgsmål kan mailes til os på:
axflow@axflow.dk

Kontor og lager:

AxFlow A/S
Kong Svends Vej 65A
DK-2765 Smørum
www.axflow.dk

FR

Pour plus d'informations sur les pompes péristaltiques realax, contactez :

AxFlow SAS
87, rue des Poiriers
ZA Sainte Apolline
78 372 PLAISIR CEDEX
Tél: +33 (0) 1 30 68 41 41
E-mail: info@axflow.fr
www.axflow.fr

HU
A realax tömlőszivattyúkkal kapcsolatos további információkért forduljon:

AxFlow Kft.
 Bilk Centre, B1 ép.
 Európa utca 6.
 1239 Budapest
 Tel.: +36 1 454-3080
 Email: axflow@axflow.hu

IE
For more information about realax hose pumps please contact:

AxFlow Ltd.
 Unit 33, Western Parkway Business Centre
 Ballymount Road
 Dublin 12
 Tel : +353 1 4504522
 Fax : +353 1 4504887
 www.axflow.ie

IT
Per assistenza tecnica e/o maggiori informazioni sulle pompe realax contattare:

AxFlow S.r.l.
 Via Montefeltro 4
 20156 Milano (MI)
 Telefono: +39 02 484801
 E-mail: info@axflow.it
 www.axflow.it

PL
Aby uzyskać więcej informacji na temat pomp realax węża prosimy o kontakt:

AxFlow Sp. z o. o.
 ul. Floriana 3/5
 04-664 Warszawa
 Telefon centrala: +48 613 00 12

Wsparcie techniczne Pompy:

wewn. 223 lub kom. +48 691 978 211,
 wewn. 254 lub kom. +48 667 856 565

Wsparcie techniczne części zamienne:

wewn. 218 lub kom. +48 667 808 878
 Pompy rejon Północ: +48 601 816 003
 Pompy rejon Centrum: +48 601 358 507
 Pompy rejon Południe: +48 605 737 091

Serwis:

wewn. 253, lub kom: +48 601 91 27 72

Realizacje dostaw:

wewn. 229, 240
 Fax: +48 815 31 16
 E-mail: biuro@axflow.pl
 www.axflow.pl

RO
Pentru mai multe informații despre pompele cu furtun realax vă rugăm să contactați:

AxFlow SRL
 Str. Henri Barbusse, Nr. 19
 RO 400616 Cluj-Napoca
 Tel.: +40 733072124
 E-mail: axflow.romania@axflow.hu

SE

För mer information om realax slangpumpar vänligen kontakta:

AxFlow AB
Ostmästargränd 12
120 40 Årsta
(Box 90162, 120 22 Stockholm)
Telefon: +46 8-602 22 00
Fax: +46 8-91 66 66
E-post: kundservice@axflow.se
www.axflow.se

SLO

Za servisiranje i podršku vaših realax peristaltičkih pumpi sa obratite se na adresu:

VIP Tehnika d.o.o.
– Member of AxFlow Group
Zgornji Duplek 30e
2241 Spodnji Duplek
Tel.: +386 2 684 00 60
Fax: +386 2 681 01 62
E-Mail: vip.tehnika@siol.net

SER

Za više informacija o realax peristaltičkim pumpama obratite se na adresu:

Regionalni menadžer prodaje
Ognjen Nešović
Mob: +381 64/84 07 079
E-mail: ognjen.nesovic@axflow.rs
www.axflow.rs

UK

For service and support to your realax hose pumps please contact:

AxFlow Services
Phone: +44 1484 543649
Fax: +44 1484 512608
E-mail: service@axflow.co.uk

For more information about realax hose pumps please contact:

AxFlow London head office
Orion Park, Northfield Ave, Ealing,
London, W13 9SJ
Phone: +44 20 85792111

AxFlow Scotland

Unit 3, Harlaw Centre, Howe Moss
Crescent, Kirkhill Industrial Estate,
Dyce, Aberdeen, AB21 OGN
Phone: +44 1224 729367

AxFlow Huddersfield

Unit 9a, Fieldhouse Business Park,
Old Fieldhouse Lane,
Huddersfield, HD2 1FA
Phone: +44 1484 543649

AxFlow Durham

Unit 31, Evans Business Centre,
Aycliffe Business Park, Newton
Aycliffe, County Durham, DL5 6ZF
Phone: +44 1325 327322

AxFlow Windsor





Unit 5, Millside Park, Crouch Lane,
Winkfield, Windsor,
Berkshire, SL4 4PX
Phone: +44 1344 886633
www.axflow.co.uk

CUSTOMER:		PHONE:	
CONTACT:		FAX:	

INTENTION:	Repair	<input type="checkbox"/>	Warranty	<input type="checkbox"/>	Return	<input type="checkbox"/>
MATERIAL DELIVERED:	Pump only	<input type="checkbox"/>	Complete unit	<input type="checkbox"/>	Spare part	<input type="checkbox"/>
UNITS:						

PUMP TYPE:	
PUMP REFERENCE:	
SERIAL NUMBER:	
OPERATION TIME (Years):	
OPERATING HOURS (h/day):	

APPLICATION DATA (* Indicate units):						
PRODUCT						
VISCOSITY *						
DENSITY *						
FLOW *						
DANGEROUS	Corrosive	<input type="checkbox"/>	Flammable	<input type="checkbox"/>	Toxic	<input type="checkbox"/>
SPEED (rev/min)	Min.		Max.			
SUCTION PRESSURE (BAR)						
DISCHARGE PRESSURE (BAR)						
TEMPERATURE (°C)						

MEDIA AND WARNINGS	   							
	Medium / Concentration	Identifica-tion	Flammable	Toxic	Corrosive	Harmful / Irritant	Other*	Harmless
Process Medium								
Medium for process cleaning								
Returned part cleaned with...								

*Explosive; Oxidising; Dangerous for the environment, Biological Risk, Radioactive. Please tick if one of the above is applicable, include MSDS and, if necessary, special handling instructions.

DESCRIPTION OF FAILURE:	

PHOTOS AVAILABLE:	Yes	<input type="checkbox"/>	No	<input type="checkbox"/>
-------------------	-----	--------------------------	----	--------------------------

The pump(s) should be emptied and cleaned of any contamination before it is sent. In case of a corrosive, flammable or toxic, product the pumps must be accompanied by a certificate of decontamination. Make sure the cleaning product you use is compatible with the materials that make up the pump and do not cause damage. In case of default we reserve the right to charge the costs of cleaning or returning the pump if necessary. By signing this form you confirm that you have cleaned the pump(s) in accordance with our recommendation.

**We hereby certify that the parts have been carefully cleaned.
To the best of our knowledge they are free from any residues in dangerous quantities.**

COMPANY/STAMP:		
DATE:	NAME:	SIGNATURE:

realax

ALL THE HOSE PUMP YOU'LL EVER NEED

www.realaxpumps.com